



IMA SCHELLING
GROUP



BIMA Px80 | E | R

Hightech machining centre for individual production tasks

imaschelling.com

BIMA Px80 | E | R

Maximale Qualität mit der IMA Portal-Baureihe

Our modular design BIMA Px80 gantry machine is a cost-efficient solution that will enable you to meet your customers' every need with flexibility, precision and speed, giving you a clear advantage over the competition. By investing in our ergonomically designed machine technology, you can be sure that your money is safe for the future. Leading Technologies – for you, this means more than 60 years of cutting-edge IMA Schelling technology with tailor-made concepts.

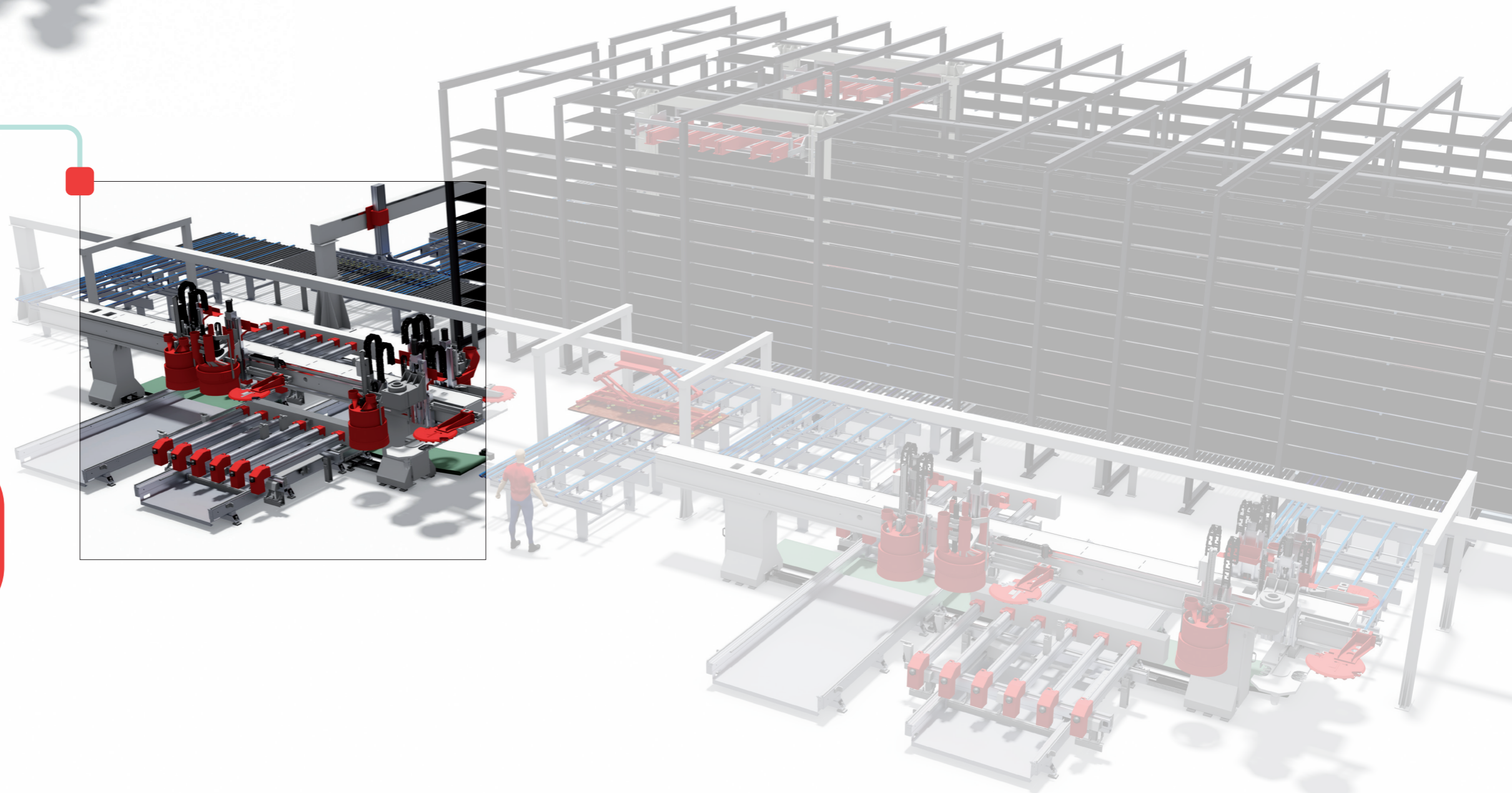
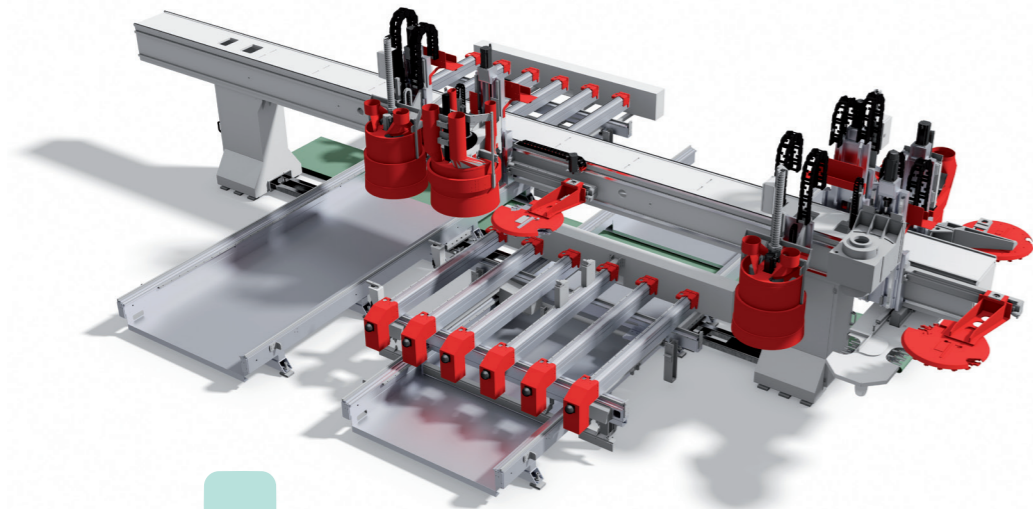

FULLY AUTOMATIC
PRODUCTION CELL
WITH BIMA Px80 E

BIMA Px80
EN 02/2022



Energy-efficient production

The protection of the environment and energy-efficiency are standard features of the BIMA Px80: Examples of this include the integrated standby mode, optimized extraction of the processing units, minimal usage of compressed air and even energy-efficient drive technology.

OVERVIEW

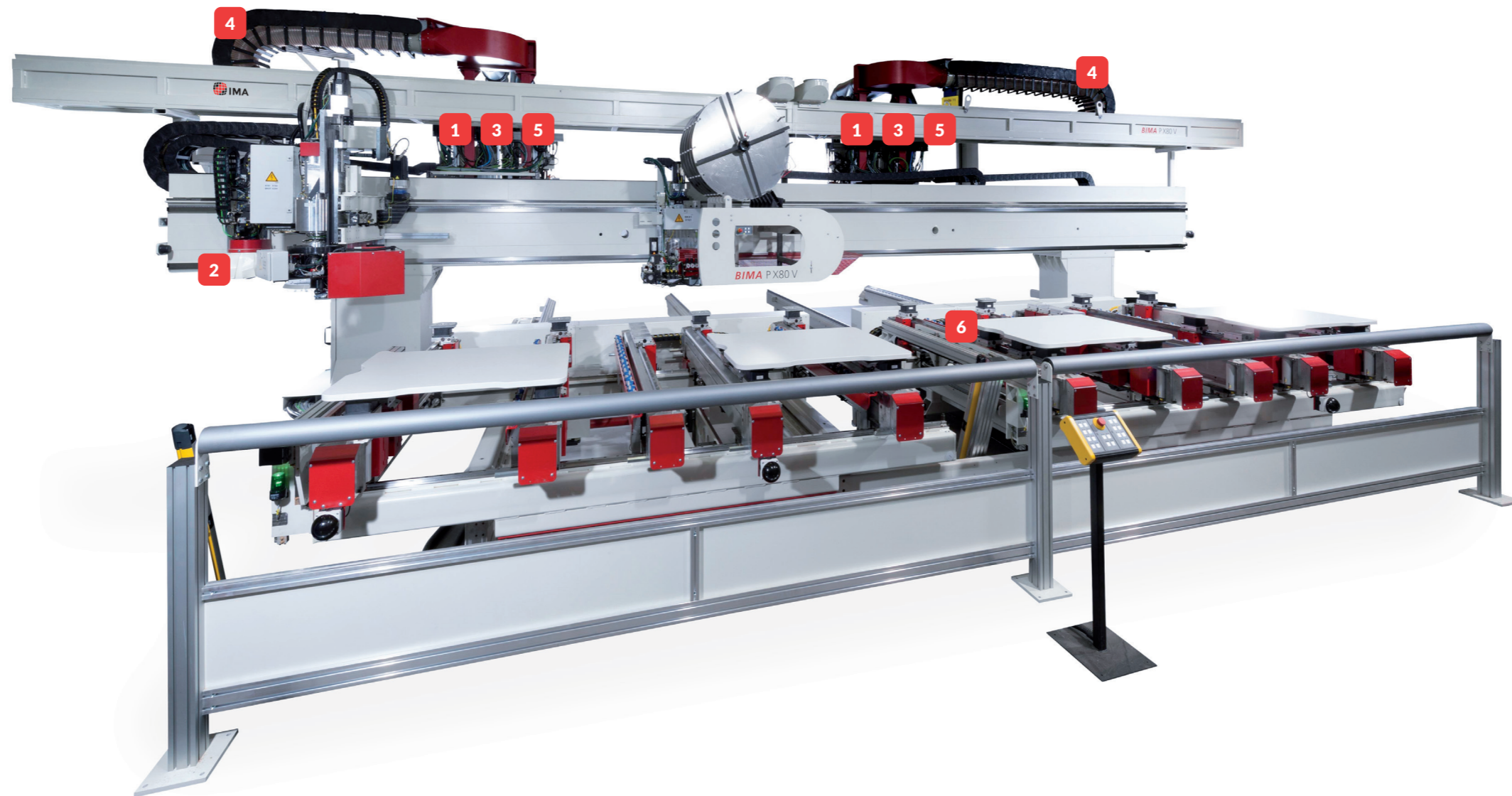

MACHINING UNIT

customer-specific equipment options

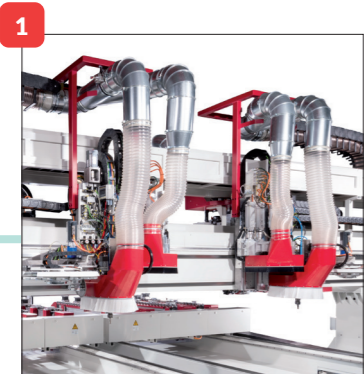

ZERO-JOINT-TECHNOLOGY

optional laser unit

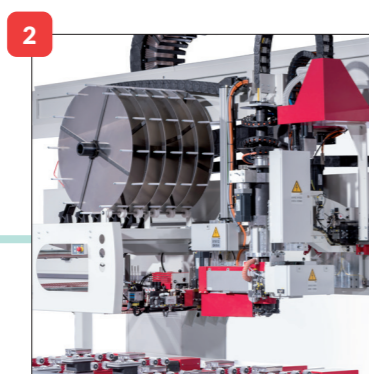

5-AXIS ROBOT HEAD

in the third dimension

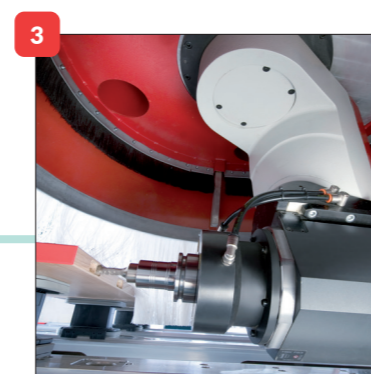

INTEGRATED EXTRACTION CONCEPT

a reduced height



MULTIFUNCTIONAL PPU HEAD

drilling/milling/grooving at any angle of rotation

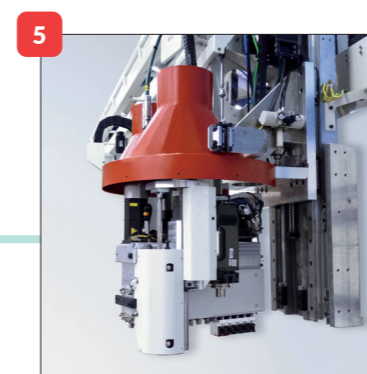

HIGHLY FLEXIBLE TABLE SYSTEMS

adjustment in seconds





DETAILS ON THE SERIES

**With IMA Schelling to maximum quality -
High-tech for your success: the BIMA Px80**

The BIMA Px80 high-performance gantry-type machine gives you new and especially innovative solutions for your applications. Whether while working in the third dimension with a 5-axis head, producing free-form parts with no seam through the patented Laser Edging System or the innovative, patented automatically adjustable combined adapter post-processing unit, the BIMA Px80 series gives you all the advantages in your production so that you can gain a competitive edge.

The superordinated processing of format and edge on the tandem tables, the synchronous machining of complex work piece geometries or possible shuttle machining and the optional connection of fully automatic feeding and stacking systems for incorporation into your production work flow increase the productivity of your machine enormously. The BIMA Px80 can be adapted very easily to your individual production requirements.

MACHINE VERSIONS

The BIMA Px80 E Concept is ideally tailored to customer needs. It permits milling, drilling and edging with the accustomed IMA Schelling quality at the highest level.

BIMA Px80 CONCEPT

- 2 independent main spindles
- 2 tool changers running in parallel, 18x, with direct drive
- 2 drilling heads on a separate Z-axis
- VT100 gluing unit with 2-fold roll magazines running in parallel
- console table

BIMA Px80 SYSTEMS

In order to be able to react to any challenges in the market the Systems Series of the BIMA Px80 offers a module that can implement the most complex requirements for production in an economic way.:

- up to 4 main spindles
- combination of 4-axis and 5-axis spindles
- up to 136 tool changer slots
- multiple drilling heads on a separate Z-axis
- Laser Edging or conventional gluing (also possible separately)
- table configuration according to the application requirements
- incorporation into production concepts by means of handling systems
- greatest possible flexibility for the maximum production output
 - production with few workers through incorporation into automatic production cells

ADDITIONAL EQUIPMENT

- automatic central lubrication standard
- air conditioning unit for switch cabinet as standard
- waste disposal
- vacuum pumps 100–250 m³
- LED setup aider (console table)
- automatically controlled support bars with rollers on all sides
- additional spindle
- lubrication unit for minimum quantities for the aluminium processing
- crosshead grooving rotatable through 90°
- various vacuum clamping systems
- horizontal, vertical clamping systems
- various adapter units and customer-specific drilling units
- teleservice or VPN

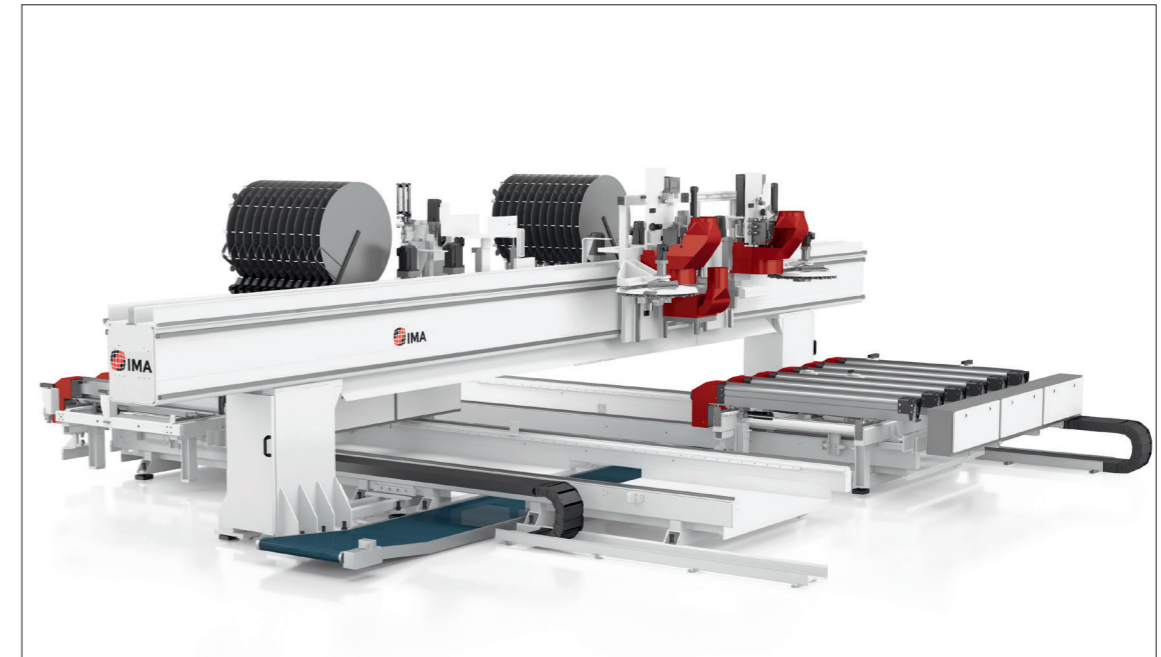

Special machine with laser unit and 24-fold edge magazine

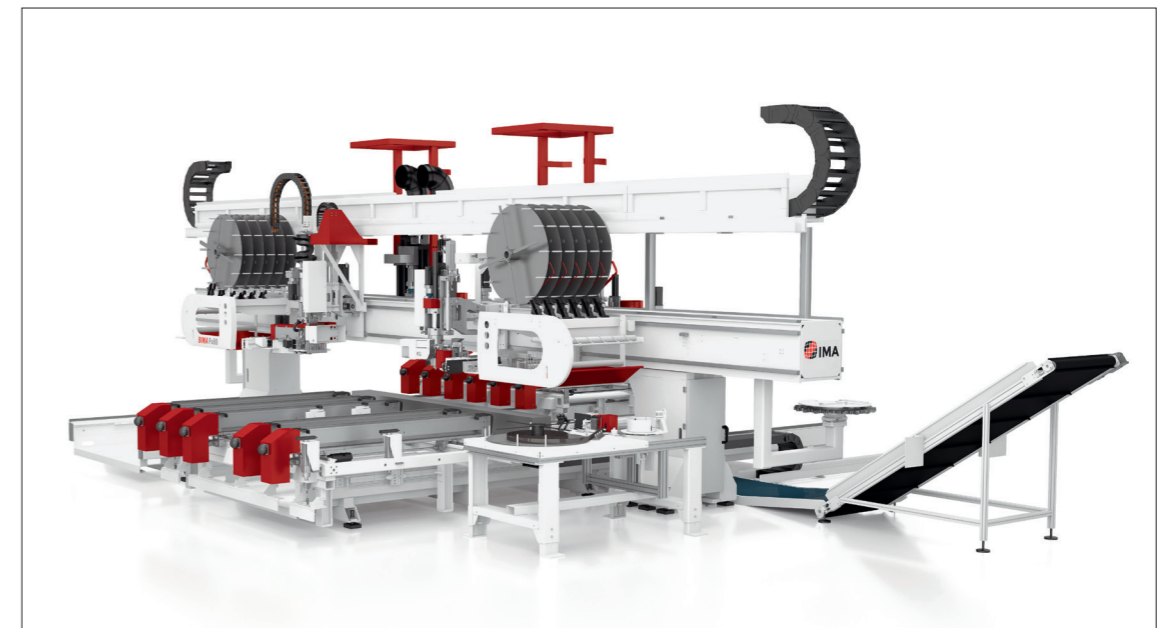

Special machine with two separately mounted edging units (gluing unit VT100/laser unit)

MACHINING STRATEGIES

The optimal combination when using BIMA Px80 processing units always guarantees high productivity for the user with full flexibility of the machine.

QUICK TOOL CHANGE

- both spindles work on the same part on one table
- parallel tool changing allowed
- the tool changing times are minimised, the productivity of the machine is thus greatly increased

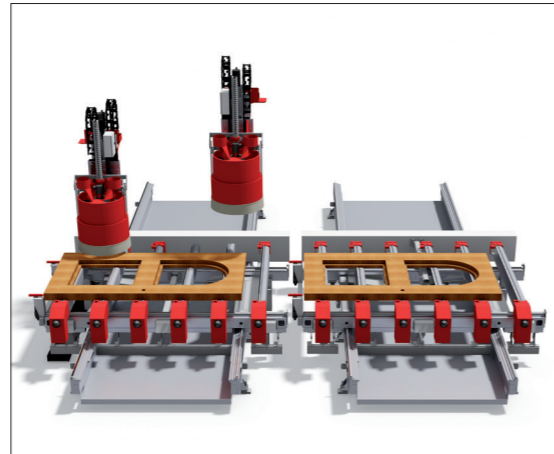
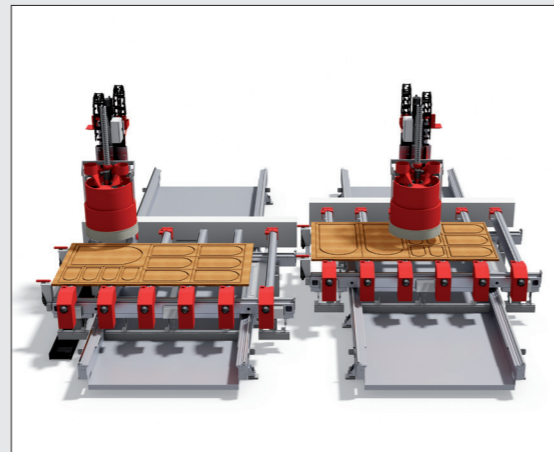

TABLE-RELATED PRODUCTION

- each spindle works on a table as if two machines are in use
- identical or differing parts are machined in parallel
- greatest possible productivity with maximum flexibility



PARALLEL PROCESSING

- both spindles work on one table on different workpieces
- the machining times are halved, productivity is doubled

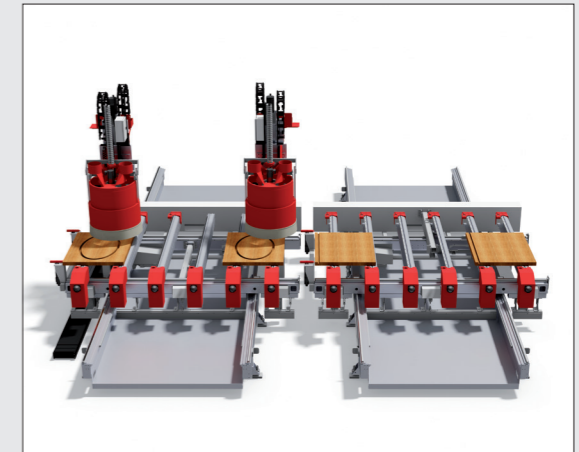

MULTI-STATION USAGE

- both tables can be equipped with additional détente stops to allow 4-fold usage per table
- all kinds of workpieces in one clamping operation on the table possible
- high productivity with a low amount of manual operation

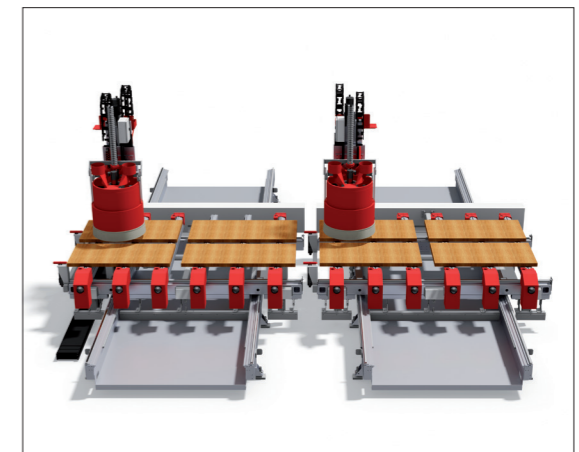

TABLE DESIGNS

Several systems are available for the BIMA Px80 series. You can choose from the whole range of workholding technologies individually tailored to your parts.



Dynapoint table

AUTOMATIC SETTING TABLE/DYNAPOINT

- fully automatic setup systems, no manual intervention required
- maximum positioning accuracy with positioning on linear guides for failure free operation and economic lifetime
- minimum positioning times to increase the productivity of the machine
- maximum independent positioning dynamics thanks to vacuum clamping block with separate Y drive (Dynapoint only)
- vacuumers can be rotated manually in a 15° grid

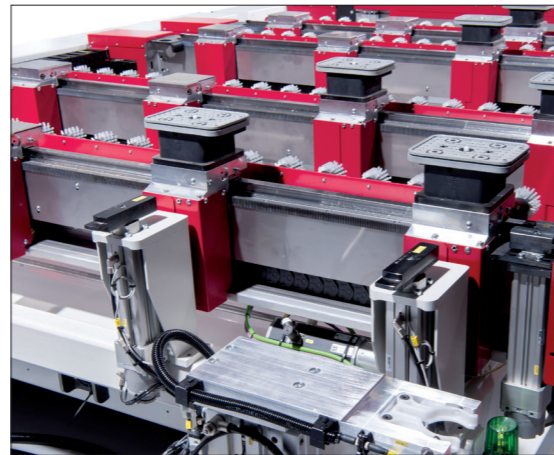

Dynapoint table

CONSOLE TABLE

- quick and safe, manual setup thanks to LED
- significant reduction in setup time (up to 70%) and increase in machine availability in contrast to conventional systems
- automatic suggestion for vacuum setting with IMAWOP



Console table: fast and reliable set up



Pattern table: maximum flexibility even when faced with challenging contours

PATTERN TABLE

- maximum flexibility even in demanding applications contours
- performance in timber or aluminum
- by the possible use of vacuum modules in different heights the raster table is suitable also for the usage of adapter units
- customer-designed stop configuration possible

MOUNTING OPTIONS

IMA Schelling high-performance drilling heads with 14–22 vertical drilling spindles and integrated interfaces for additional units or machining spindles make it possible for the BIMA Px80 to be ideally adapted to customer requirements.

DRILLING HEAD I14 OR I21

- integrated Z-axis
- 14 or 21 vertical drilling spindles, belt-driven
- 4 x 1.2 kW drive rating
- up to 9,000 rpm, variable
- only clockwise-turning drill
- integrated cross-head, 90° sawing unit or horizontal drilling unit
- optional: free space for quality additional spindle
- special drilling heads possible if required

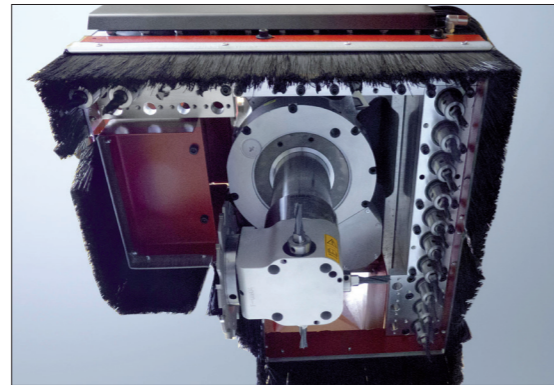

High-performance drilling head and cross-head with grooving saw, swivelling

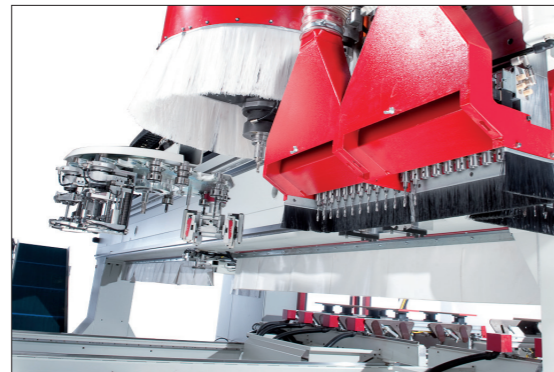

High-performance drilling head to special configuration

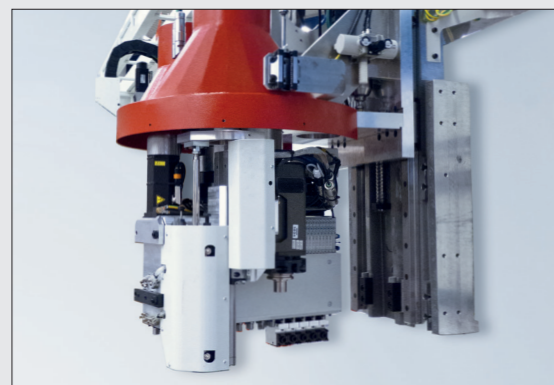

Multifunction unit PPU 360°

MULTIFUNCTION UNIT PPU 360°

- 22 vertical drilling spindles
- 10 horizontal drilling spindles
- integrated 90° mitring/grooving saw
- free space for optional 9 kW secondary spindle with tool holder HSK-F63 incl. entry for adapter units

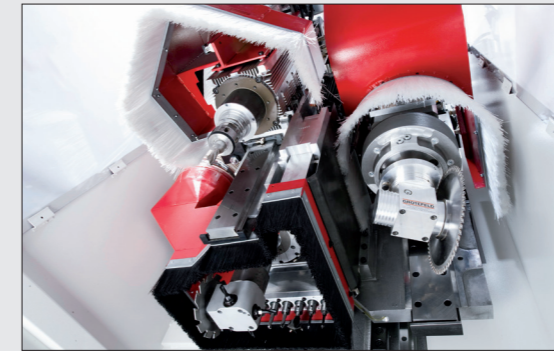

Main spindle with additional spindle and high-performance drilling head

MAIN SPINDLES

- vector-controlled, max. 24,000 rpm
- power range from 10 kW (S6), 18 kW (S6) or 27 kW (S6)
- interpolating C-axis 360°
- optional electronic sensing for perfect workpiece quality
- optional vibration sensors to protect the spindles against workpiece imbalance
- optional electronic interface for automatically adjustable combined adapter units
- adequate additional spindle 10 kW (S6) with HSK-F63 tool holder

TOOL CHANGE SYSTEMS

- optionally, up to 136 tool slots
- 18-fold tool change carousel travelling in parallel, servo-controlled, slot-optimised positioning for shortest possible tool changing times
- optional 8-fold tool change carousel travelling in parallel
- up to 72-fold chain-type tool changers per gantry side possible, slot-optimised positioning for shortest possible tool changing times

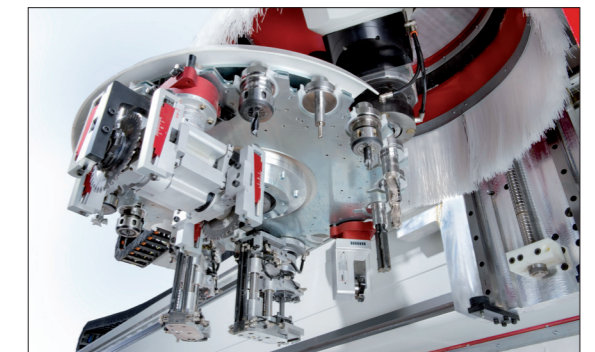

18-fold tool change carousel travelling in parallel, servo-controlled

5-AXIS ROBOT HEAD

- 5-axis head with cardan joint bearing and 18 kW work spindle (motor duty type S6)
- Unit interface with transmission of pneumatic and hydraulic fluid power
- optional extraction with integrated Z axis for optimal extraction results even with 5-axis machining



Robot head with endlessly rotating A- and C-axes

CONVENTIONAL GLUING

More than 30 years ago IMA Schelling built the first processing centre in the world with an edging unit for the processing of free-form parts. Up until today IMA Schelling holds the patents for this technology, which has constantly been developed further.

EDGING UNIT VERSIONS:

- VT50
- VT100
- VT100/100

EQUIPPING OPTIONS/VERSIONS:

- 90° inside corner gluing
- automatic edging unit with continuously variable angle VT100/100 for slanted edge gluing on areas up to 45°
- PU-gluing
- edges magazine running in parallel, up to 24-fold (stationary up to 36-fold)
- edge cassette for delicate edging strip materials (e.g. veneer)
- mitring saw, also sensing mitring, on the gluing side (saves tool changing) to increase productivity

HIGHLIGHTS OF THE IMA TECHNOLOGY

- built-in collision control (patent) from VT100 as standard for protection against damage due to operation errors
- foldable (patent) for easy cleaning
- edge height up to 100 mm (VT100/100)
- optional automatic edge height adjustment in the edge magazine and gluing unit
- butt joint gluing on very small workpieces extends the production facilities
- superlative work piece quality through consistent amounts of glue, also with changing speeds

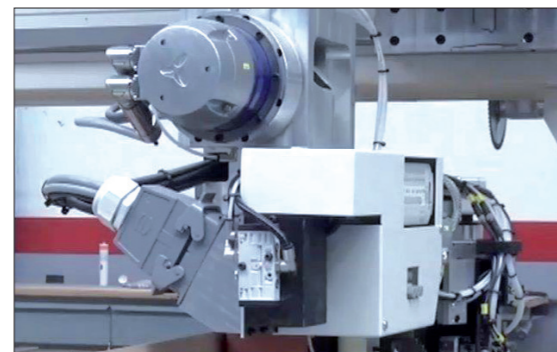

Edging unit VT100/100 with automatic adjustment tiltable axis

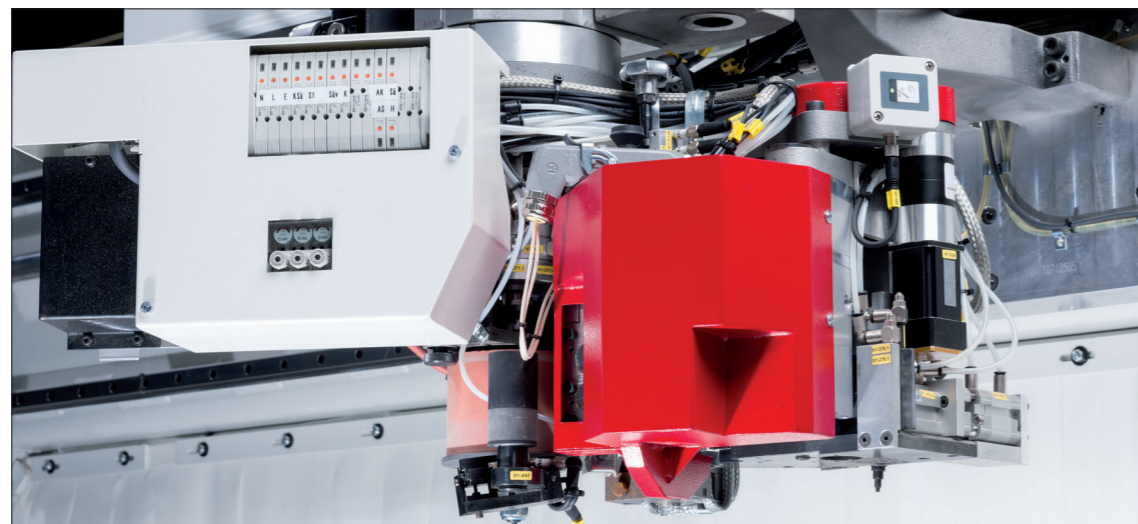

Proven technology: VT100 edging unit

IMA LASER EDGING

The high-performance Edging System that has been further developed permits the production of free-form parts with no seam. Optionally available as well as a combined unit in the latest generation with unit that can be set up manually for EVA or PUR gluing in just one unit.

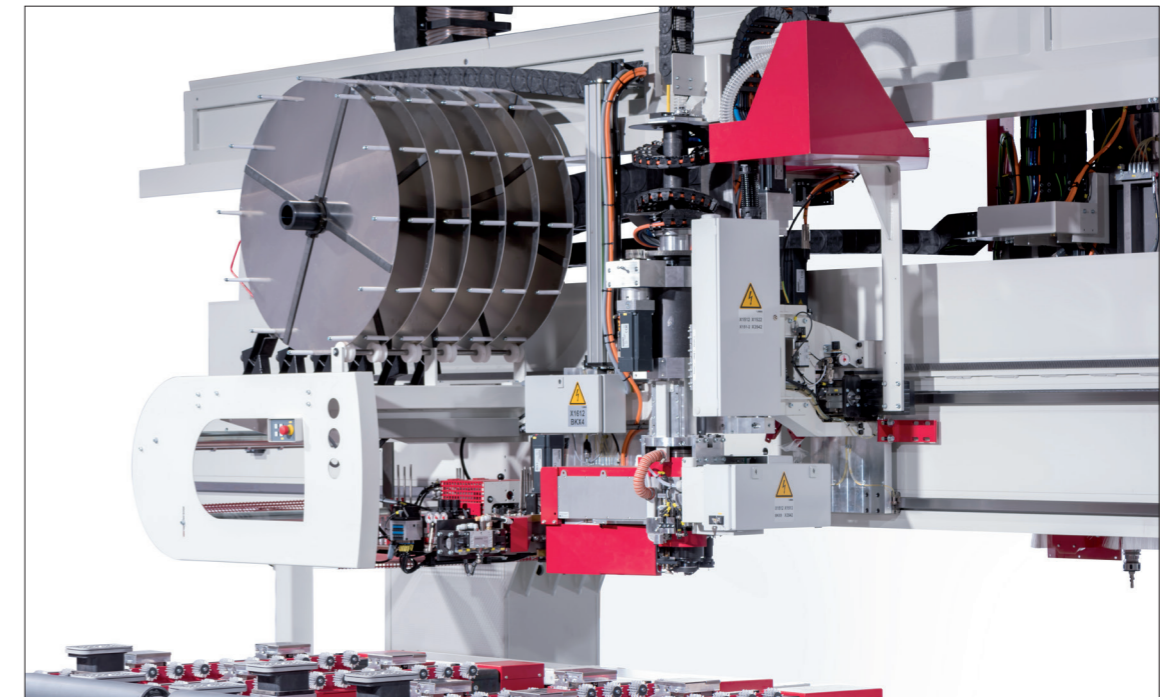

laser unit with 6-fold edges magazine

HIGHLIGHTS OF IMA LASER TECHNOLOGY

- combined unit for EVA, PUR and laser edging by manual conversion for full flexibility in future (optional)
- patented collision control for damage protection
- all required adjustments on the unit are program controlled
- thanks to zoom optics with an integrated lens system wear-free laser unit
- manually replaceable pressing roller from 100 mm to 50 mm

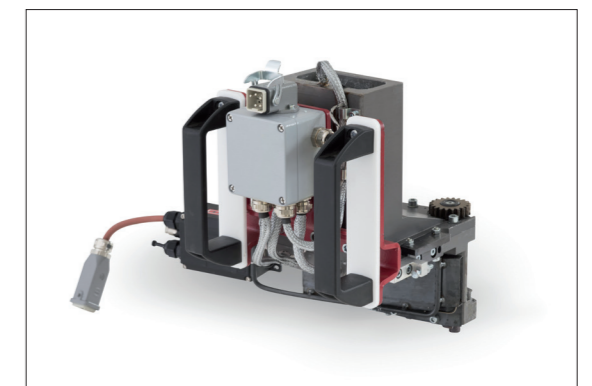

Manual changeover set from laser to gluing processing

FINISH

A perfect finishing creates perfect results for your workpieces:
Whether the innovative full-automatic steered finishing unit
AEK (patent) with up to 3 different radii in one unit, or the
keyed capping and corner cutting.

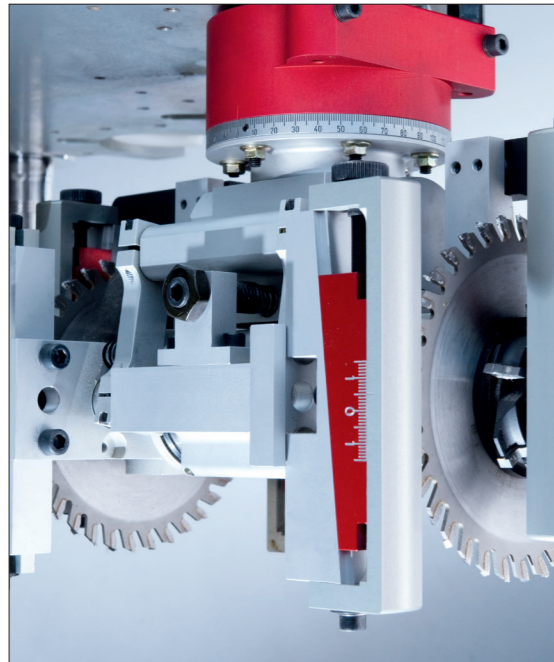

Sensing of mitres/rounded corners for up to 2 profiles

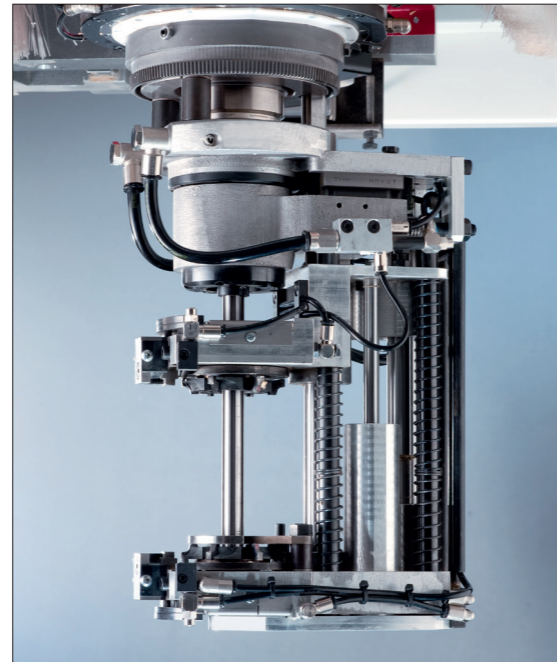

combined unit: complete post-processing with just one tool change

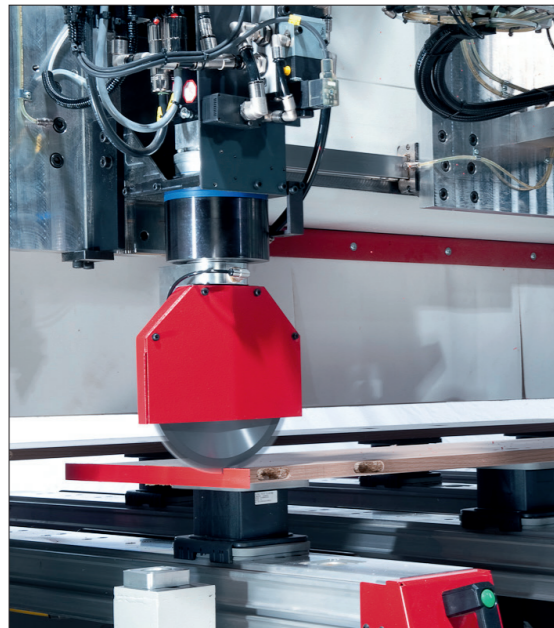

Mitring saw on the gluing side to minimise tool change times

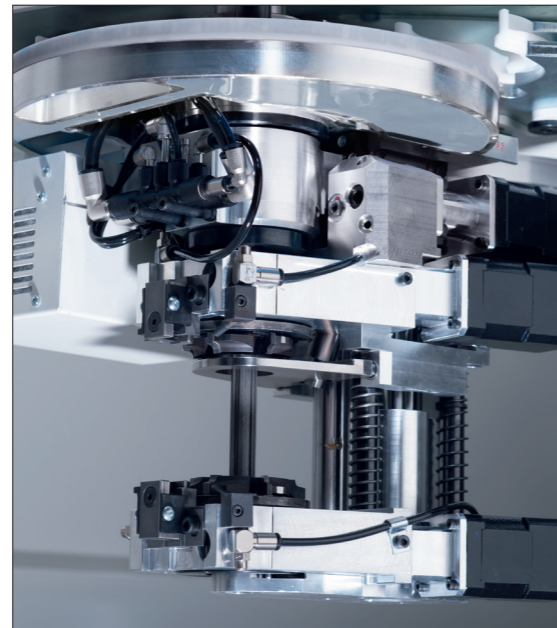

Fully automatically adjustable combined adapter post-processing unit without the need to set it up, for the perfect finish

OTHER EQUIPMENT

Adjusted to every abandonment of production, additional
machine equipment allows an ideal integration of the
manufacturing machine in your production.

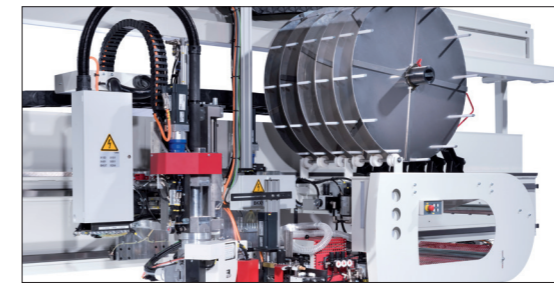

6-fold edge magazine, servo-controlled



12-fold edge magazine, servo-controlled



Integrated extraction concept for reduced height (optional)

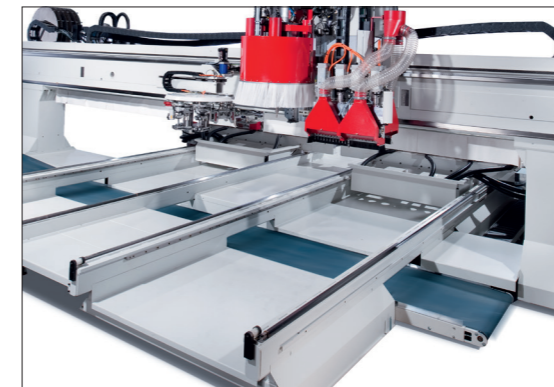

Optimised chip and waste disposal (optional)

EDGE MAGAZINE

- servo-controlled edge magazine with automatic push-type changing and automatic edge height setting
- minimal cutting waste due to servo-control
- optimal edge tracking running in parallel
- optionally can be configured for special edging materials
- edge magazine running in parallel up to 24-fold (stationary up to 36-fold)
- detection in the controller of the remaining length of the edge to avoid scrapped parts or reworking

EDGE CASSETTE

- edge cassette for the gentle processing of delicate edging materials or long edge lengths increases the process reliability of the machine

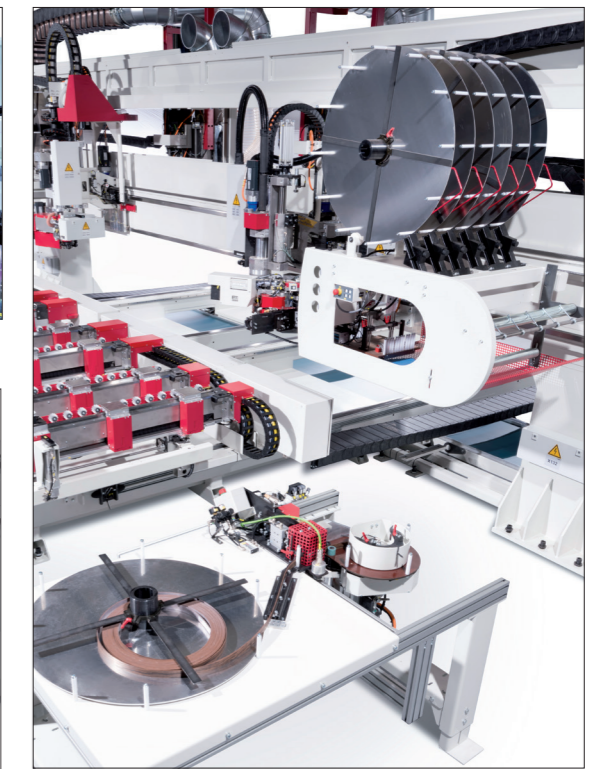

Edge cassette with up to 6-fold roll holders

IMAWOP

IMAWOP is the ideal operating control system with practice - tested software for flexible fabrication of different work tools. It is currently equipped with automatic preset setup time and working programs. Work tool movement and processing procedures can be simulated in 3D - for highest possible performance and safety.

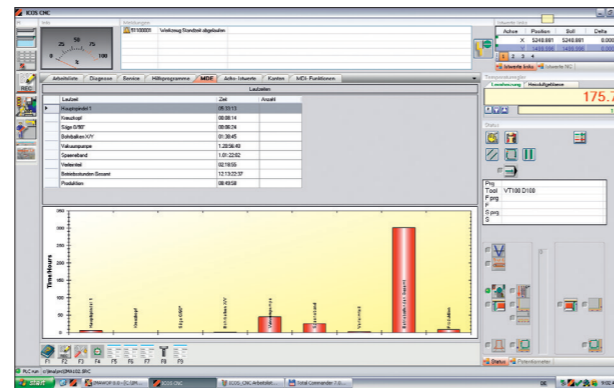

IMAWOP CONTROL - OVERVIEW

- simple, graphic user interface/menu guidance - easy usability
- barcode, hand scanner
- five-sided machining
- creation or take-over of CAD drawings of panels if required
- automatic recording of statistical operating data such as unit numbers, production and production costs working hours etc.
- dynamic 3D auxiliary graphics for intuitive data entry
- safe and easy operation by 3D simulation, automatic vacuum calculation and graphical placement manager
- IMA Quicktool for fully automatic machine independent CNC programming for lot-size-1
- process and processing time optimisation
- 3D interface for SolidWorks® and TopSolid®
- time recording
- DXF interface
- compatible controller system for all current network solutions
- Windows®-based user interface

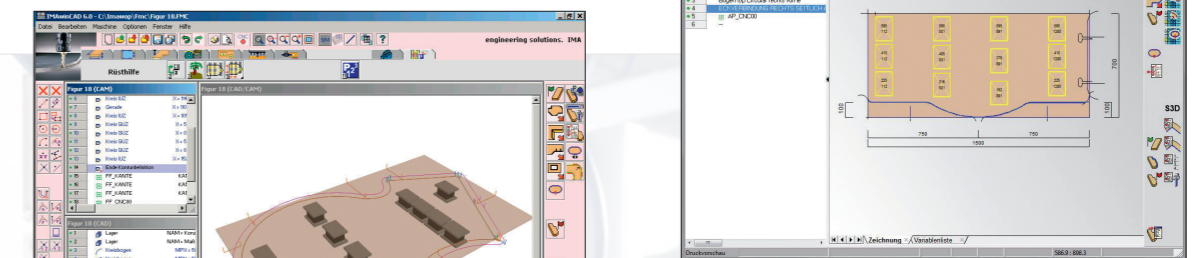

SYSTEM SOLUTIONS

THE INTEGRATION OF A BIMA Px80 E INTO FULLY AUTOMATIC PRODUCTION PERMITS OPERATION OF THE MACHINE WITH FEW WORKERS AND WITH MAXIMUM OUTPUT.

You benefit twice from the integration of the BIMA Px80 high-performance gantry machine to automatic IMA feeding and stacking systems: highly efficient processing machines in connection with automatic supplying mean the best possible workpiece quality while reducing the load on the workers and while increasing productivity at the same time. The BIMA Px80 retains its full accessibility also with manual feeding, for example, with special workpieces – despite taking up very little room. Thanks to decades of experience from the handling sector, the IMA technology provides optimal process reliability in production. The systems can be adapted flexibly to meet all production conditions. Integration into complex production systems is thus made possible as well.

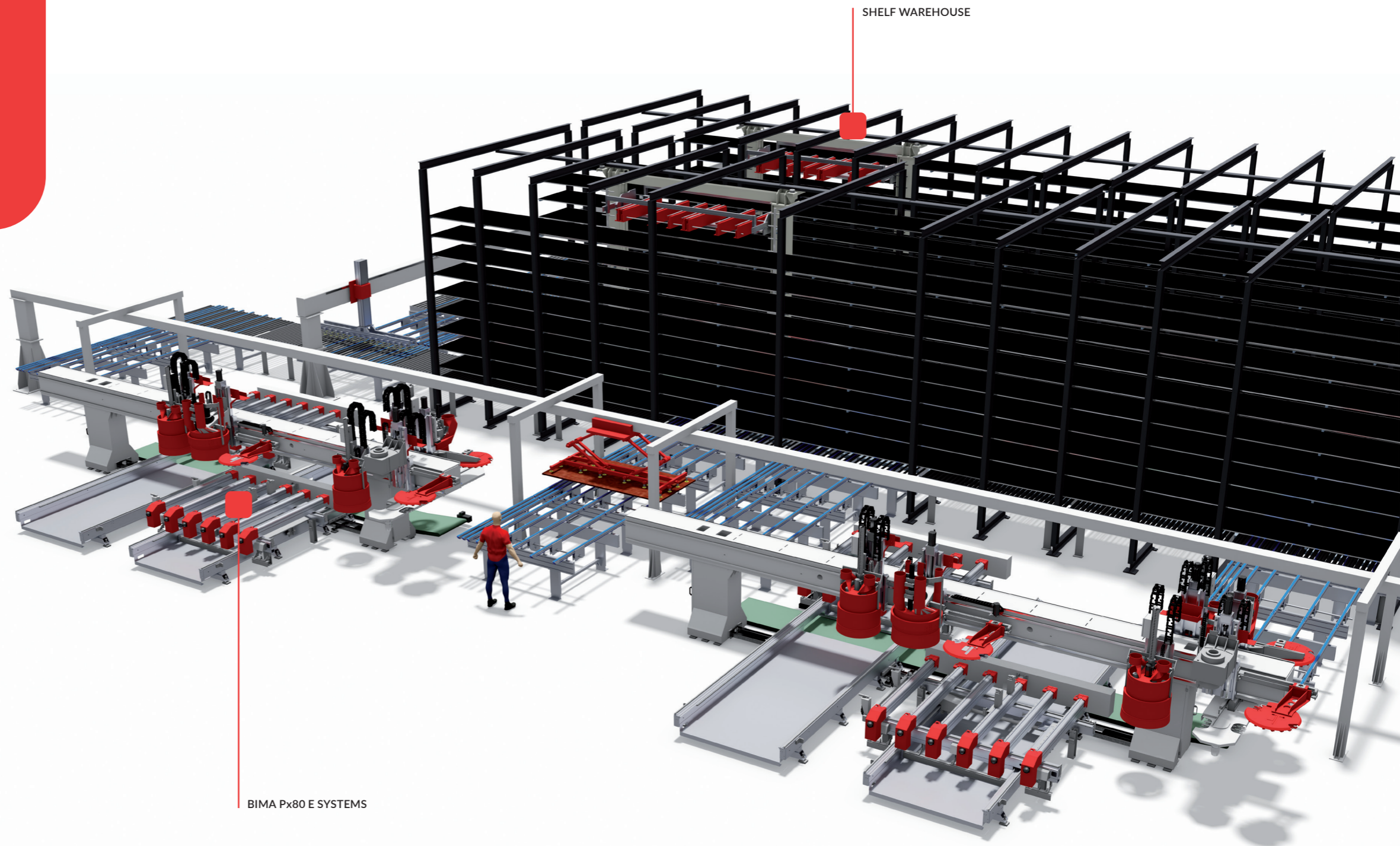

BIMA Px80 E SYSTEMS



SERVICE PLATFORM ZIMBA

ZIMBA is an Industrial Internet of Things (IIoT) data collection software and service portal that gives you valuable information and specific recommendations for maximizing efficiency and machine performance. ZIMBA helps achieving the highest productivity of IMA Schelling products throughout their lifecycle.

ZIMBA
MACHINES, HOW ARE YOU?



ZIMBA ASSISTANCE APP

IMA Schelling stands for innovative and customized solutions providing the highest quality. It requires high quality support all the way from planning stage through engineering and software to assembly, start-up and aftersales services.

The ZIMBA Assistance App connects employees on site with in-house experts in an interactive video conference. That in turn enables us to provide customers with a fast and simple solution.



ZIMBA TICKET APP

Professional, simple and fast. The ZIMBA Ticket App supports you with any tasks regarding your machines.

The App has been designed for the IMA Schelling service portal in order to have access to machine documents, our ticket and support system as well as maintenance management .

TECHNICAL DATA

BIMA Px80 BIMA Px80 E BIMA Px80 E | R

OPERATING RANGE including work-holding device			
X-direction	2 x 2500 (5100) mm/ 2 x 3250 (6600) mm	2 x 2500 (5100) mm/ 2 x 3250 (6600) mm	2 x 2500 (5100) mm/ 2 x 3250 (6600) mm
Y-direction	1400 mm, 1800 mm, 2200 mm		
Z-direction	225 mm		350 mm
MACHINE			
Main spindle (S6 operation)	10 kW, 18 kW or 27 kW		18 kW
Tool changer	8- to 18-fold travelling with head assembly in X direction 40-/50-/72-fold		
C-axis	interpolating C-axis 360°		5-axis robot head with cardan joint bearing
drill heads	vertical spindles: 14, 21 or 22 (multi-function drill head 360°) horizontal spindles: max. 12		
Edging		VT50/VT100/VT100/100 or diode laser	
Number of support rails	6/8/10/12		
Sound level	Operation without processing 80 dBA (dependent on tools, feed speed and material)		
Central extraction connection	Ø 250 mm with slider control		

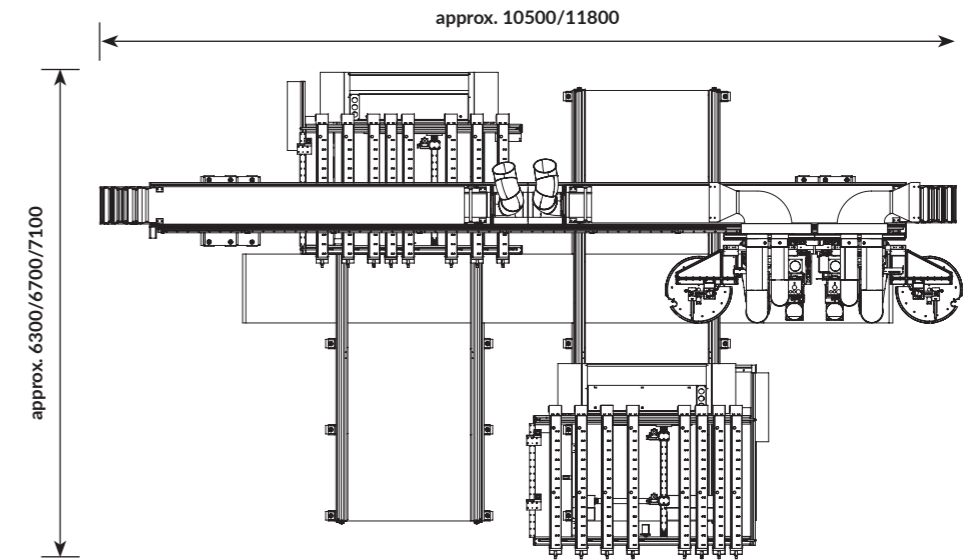

BIMA Px80

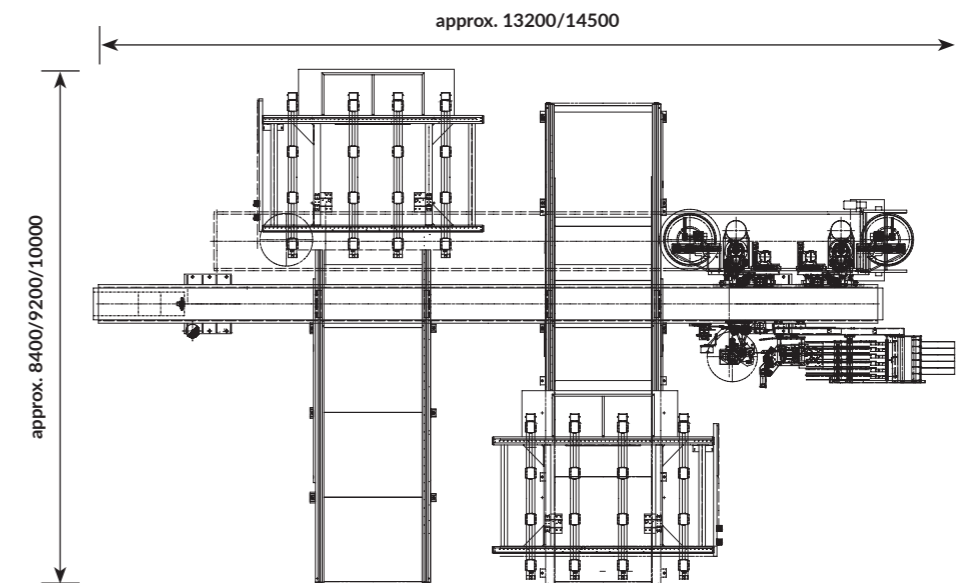

BIMA Px80 E

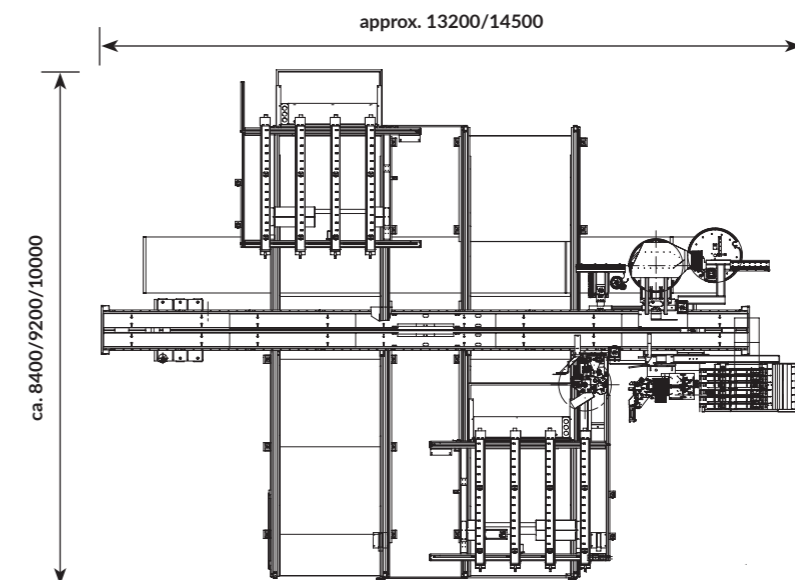

BIMA Px80 E | R

Dimensions depend on assortment!

The IMA Schelling Group is a reliable partner for implementing of sophisticated system solutions.
The demands of our customers are a daily challenge to us, our know-how and creativity! We work with you to develop innovative and unique solutions for wood processing.

www.imaschelling.com

Modifications and mistakes reserved. Illustrations are approximate. Subject to technical modifications and mendments and to further developments. The offer, respectively the order confirmation is relevant in either case! The picture of the machine could have been taken without complete protection devices.
The protection device is part of the scope of delivery. Photos could also be options, not being part of the scope of delivery and are not binding in detail.



IMA SCHELLING
GROUP